

BFM 2011

for generator sets

13 - 64 kW | 17 - 85 hp at 1500/1800 min⁻¹ | rpm
for markets without emission regulation

- Oil-cooled 2-, 3- and 4-cylinder naturally aspirated in-line engines. 4-cylinder engines also with turbocharging and optional charge air cooling.
- Direct injection with single injection pumps and optional electronic governor.
- Long oil change intervals of up to 1000 hours.



The DEUTZ Telco Engine

- Minimised running costs due to low maintenance need and little wear.
- Low fuel consumption due to optimised combustion.
- High reliability combined with durability. No corrosion or cavitation due to oil cooling and lubrication.
- A very good load response ensures an immediate power supply.

Technical data

Engine type		F2M 2011	F3M 2011	F4M 2011	BF4M 2011	BF4M 2011C
No. of cylinders		2	3	4	4	4
Bore/stroke	mm in	94/112 3.7/4.4	94/112 3.7/4.4	94/112 3.7/4.4	94/112 3.7/4.4	94/112 3.7/4.4
Displacement	l cu in	1.6 95	2.3 142	3.1 190	3.1 190	3.1 190
Weight (incl. cooler and fan)	kg lb	224 494	265 584	303 667	304 671	362 798
Governing standard ¹⁾		G2	G2	G2	G2	G2

50 Hz / 1500 min⁻¹

Power		F2M 2011	F3M 2011	F4M 2011	BF4M 2011	BF4M 2011C
Continuous Power (COP) ²⁾	kW hp	11.8 15.8	19.4 26.0	27.9 37.4	37.2 49.9	50.6 67.9
Prime Power (PRP) ³⁾	kW hp	12.4 16.6	20.4 27.4	29.4 39.4	39.2 52.6	53.3 71.5
Limited Time Power (LTP) ⁴⁾	kW hp	13.0 17.4	21.4 28.7	30.9 41.4	41.2 55.3	56.1 75.2
Typical Generator Output COP	kVA	12	20	30	40	54
Typical Generator Output PRP	kVA	12	21	32	42	57
Typical Generator Output LTP	kVA	13	22	33	44	60

60 Hz / 1800 min⁻¹

Power		F2M 2011	F3M 2011	F4M 2011	BF4M 2011	BF4M 2011C
Continuous Power (COP) ²⁾	kW hp	14.3 19.2	22.1 29.6	31.8 42.6	42.8 57.4	57.4 77.0
Prime Power (PRP) ³⁾	kW hp	15.0 20.1	23.3 31.2	33.5 44.9	45.0 60.3	60.4 81.0
Limited Time Power (LTP) ⁴⁾	kW hp	15.8 21.2	24.5 32.9	35.2 47.2	47.3 63.4	63.6 85.3
Typical Generator Output COP	kWe	11	18	27	36	48
Typical Generator Output PRP	kWe	12	19	29	38	51
Typical Generator Output LTP	kWe	13	20	30	40	53

1) According to ISO 8528-5.

2) Continuous Power: No time limitation, plus 10% additional power for governing purpose only.

3) Prime Power: Average power output ≤ 80%, no time limitation, plus 5% additional power for governing purpose only.

4) Limited Time Running Power: For up to 500 h/year, thereof a maximum of 300 h/year continuous running.

The data on this data sheet are for information purposes only and are not binding values. The data in the quotation is definitive.

50 Hz / 1500 min⁻¹

Fuel Consumption (PRP) ¹⁾		F2M 2011	F3M 2011	F4M 2011	BF4M 2011	BF4M 2011C
Fuel consumption 25% load	g/kWh lb/hph	300 0.49	300 0.49	298 0.49	253 0.42	229 0.38
Fuel consumption 50% load	g/kWh lb/hph	237 0.39	230 0.38	226 0.37	219 0.36	206 0.34
Fuel consumption 75% load	g/kWh lb/hph	222 0.36	218 0.36	217 0.36	215 0.35	206 0.34
Fuel consumption 100% load	g/kWh lb/hph	227 0.37	225 0.37	225 0.37	221 0.36	209 0.34
Heat balance & cooling system		F2M 2011	F3M 2011	F4M 2011	BF4M 2011	BF4M 2011C
Heat dissipation (engine radiator) ²⁾	kW hp	7.4 9.9	12.4 16.6	18.2 24.4	25.9 34.7	28.3 38.0
Heat dissipation (CAC) ²⁾	kW hp	-	-	-	-	7.4 9.9
Heat dissipation (convection)	kW hp	1.6 2.1	2.6 3.5	3.7 5.0	4.9 6.6	7.9 10.6
Fan power consumption	kW hp	0.4 0.5	0.4 0.5	0.4 0.5	1.0 1.3	2.1 2.8
Cooling air flow	m ³ /h cfm	1800 1059	1800 1059	1800 1059	2370 1395	3200 1883
Inlet & exhaust data		F2M 2011	F3M 2011	F4M 2011	BF4M 2011	BF4M 2011C
max. intake depression	mbar psi	20 0.29	20 0.29	20 0.29	20 0.29	20 0.29
Combustion air volume	m ³ /h cfm	57 34	86 51	122 72	168 99	241 142
max. exhaust gas temperature	°C °F	540 1004	611 1132	599 1110	611 1132	570 1058
Exhaust gas flow	m ³ /h cfm	168 99	236 139	337 198	468 275	704 414

60 Hz / 1800 min⁻¹

Fuel Consumption (PRP) ¹⁾		F2M 2011	F3M 2011	F4M 2011	BF4M 2011	BF4M 2011C
Fuel consumption 25% load	g/kWh lb/hph	317 0.52	315 0.52	280 0.46	269 0.44	242 0.40
Fuel consumption 50% load	g/kWh lb/hph	250 0.41	240 0.39	230 0.38	227 0.37	216 0.36
Fuel consumption 75% load	g/kWh lb/hph	239 0.39	228 0.37	220 0.36	223 0.37	210 0.35
Fuel consumption 100% load	g/kWh lb/hph	247 0.41	236 0.39	225 0.37	227 0.37	212 0.35
Heat balance & cooling system		F2M 2011	F3M 2011	F4M 2011	BF4M 2011	BF4M 2011C
Heat dissipation (engine radiator) ²⁾	kW hp	8.7 11.7	13.5 18.1	20.2 27.1	28.7 38.5	28.1 37.7
Heat dissipation (CAC) ²⁾	kW hp	-	-	-	-	10.6 14.2
Heat dissipation (convection)	kW hp	2.0 2.7	3.1 4.2	4.4 5.9	6.0 8.0	8.9 11.9
Fan power consumption	kW hp	0.7 0.9	0.7 0.9	0.7 0.9	1.8 2.4	3.5 4.7
Cooling air flow	m ³ /h cfm	2160 1271	2160 1271	2160 1271	2850 1677	3740 2201
Inlet & exhaust data		F2M 2011	F3M 2011	F4M 2011	BF4M 2011	BF4M 2011C
max. intake depression	mbar psi	20 0.29	20 0.29	20 0.29	20 0.29	20 0.29
Combustion air volume	m ³ /h cfm	68 40	104 61	137 81	191 112	317 187
max. exhaust gas temperature	°C °F	570 1058	580 1076	660 1220	600 1112	530 986
Exhaust gas flow	m ³ /h cfm	212 125	312 184	428 252	560 330	895 527

1) Refers to diesel with a density of 0.835 kg/dm³ at 15°C | 6.96 lb/US gallon at 60°F.

2) The heat quantities are valid for the dimensioning of the cooling system.

Dimensions

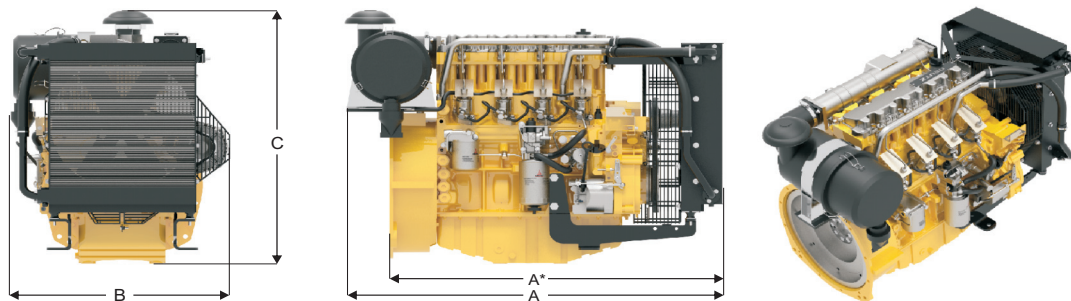

		A	A*	B	C
F2M 2011	mm in	845 33	720 28	645 25	760 30
F3M 2011	mm in	955 38	830 33	645 25	760 30
F4M 2011	mm in	1065 42	940 37	645 25	780 31
BF4M 2011	mm in	1070 42	940 37	625 25	805 32
BF4M 2011C	mm in	1185 47	1055 42	725 29	805 32

Note: The engine dimensions and weights vary depending on the scope of delivery.

For more information please contact the DEUTZ AG Köln or the responsible sales partner.

